

DOORS

LIGHT DUTY ROLL-UP



1950 SERIES

The 1950 Commercial Series is a sheet door value engineered with strength and durability in mind. The versatility and easy operation makes this door dependable, yet still economical. Backed by a one year warranty on workmanship and material, this 1950 Series is the best value on the market. The 1950 door is also available in heavy duty (HD) for medium duty application.

↑ **HEADROOM**
19" (THRU 8')
20" (8' TO 10')
↓ 20.5" (10' TO 14')

9-1/2"
DRUM

WARRANTY
40/35
FILM/CHALK-FADE

1950 SERIES

LIGHT DUTY ROLL-UP

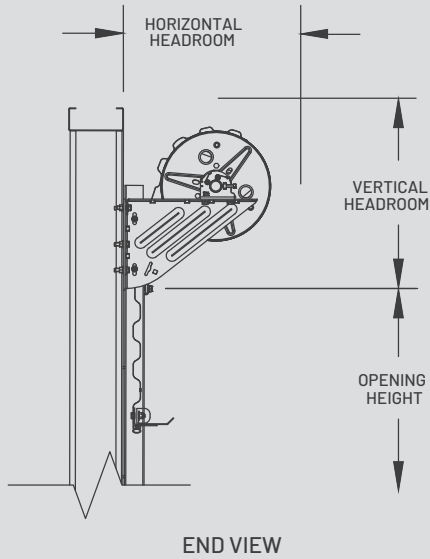

IMPORTANT NOTES:

- Dimensions are referenced from edge of opening.
- Tensioner end and drive end can be installed at either end of door assembly.
- FOR CRITICAL FITS DUE TO REDUCED AVAILABLE HEADROOM or SIDEROOM CLEARANCES, CONSULT FACTORY.

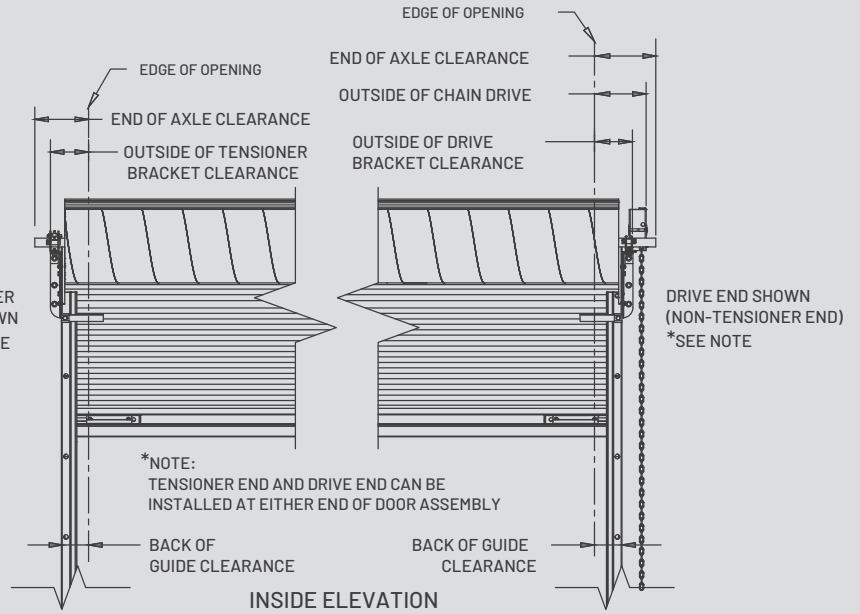

Universal mount 2.25" deep 16-gauge galvanized steel guides require no pre-installation modifications for wood, steel, concrete or filled masonry block applications.

SPECIFICATIONS

Guide Details

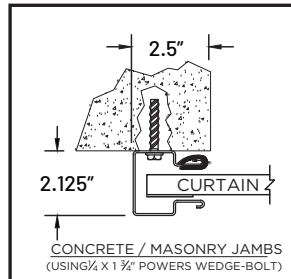
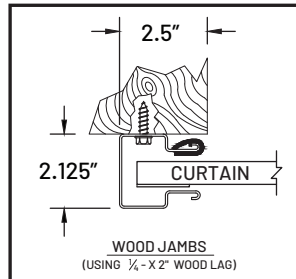
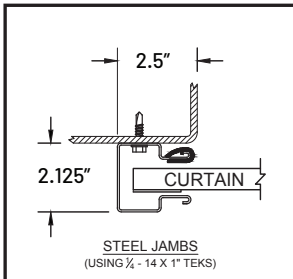

HIGHLIGHTS:

- B** Barrel: 9.5"
 - G** Guide: 2.25", 16-gauge
 - 4:1 reduced-drive chain hoist offers smoother operation on doors over 10' tall.
- Visit DBCi.com for technical drawings, color options and more.

Head Room Requirements

Opening Height	Vertical Headroom	Horizontal Headroom
Thru 8'0"	19"	19"
Over 8'0" thru 10'0"	20"	20"
Over 10'0" thru 14'0"	20.5"	20"

Side Room Requirements

Operation	Guide	Outside of Bracket Tensioner End	Outside of Hand Chain Drive	Outside of Bracket Drive End	Each End of Axle
Push Up	2.5"	4.5"	N/A	4.5"	7"
Reduced Drive Chain	2.5"	4.5"	7"	4.5"	7"
Electric	2.5"	4.5"	N/A	4.5"	7"

